

FLANGE in ACCIAIO da saldare in testa
EN 1092-1 tipo 11 pn16
(ex uni 2282-67)

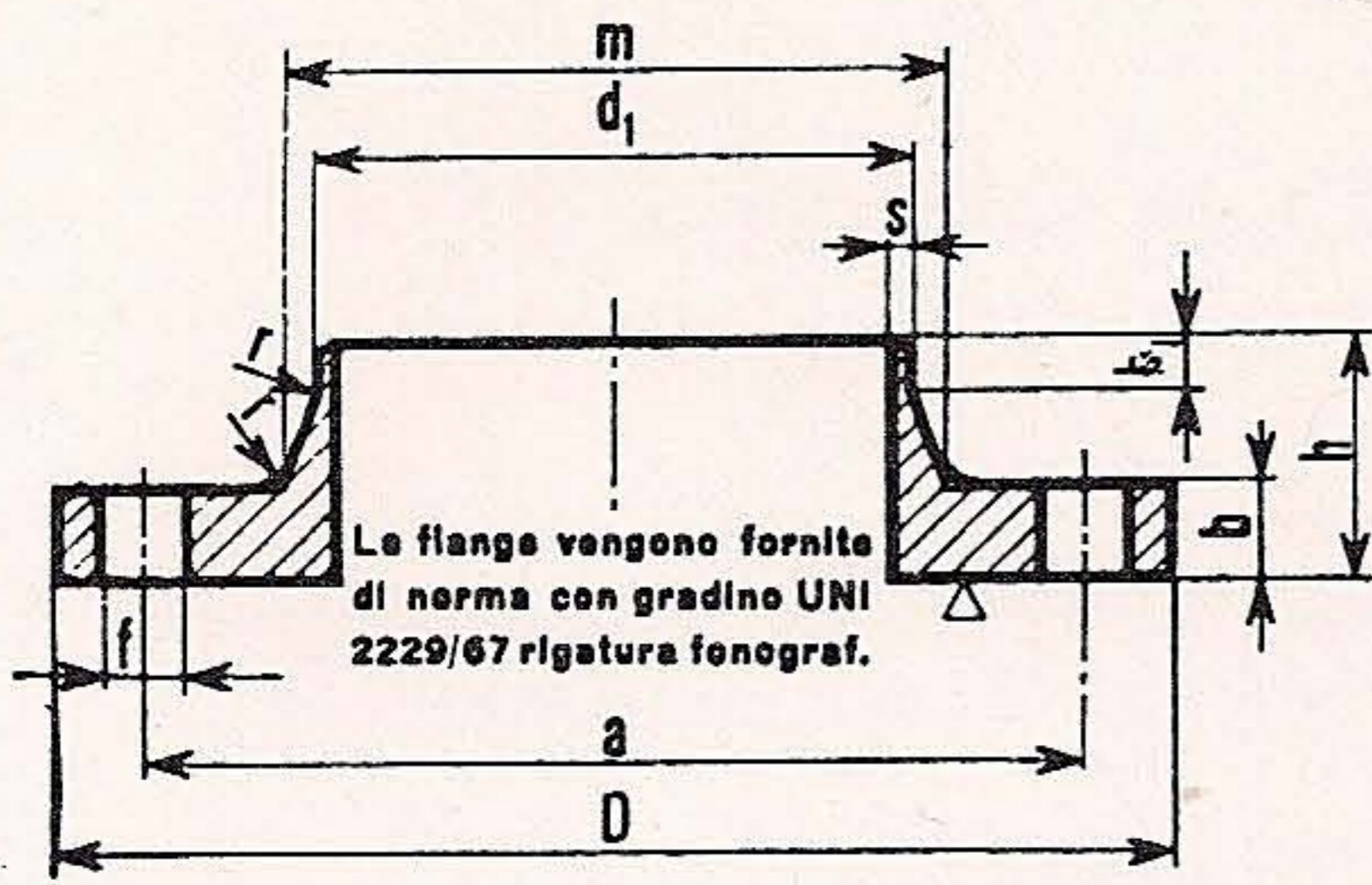

Dimensioni in mm

Ind. per la designazione	DN	Ø est.	d'	a	b	D	f	h	h'	m	r	s	N° fori	Filett. viti	Peso ca Kg
PN 16	10	13,5 17,2•	14,5 18	60	14	90	14	35	6	25 28	4	2,3	4	M 12	0,65 0,65
	15	20 21,3•	21 22,5	65	14	95	14	35	6	30 32	4	2,5	4	M 12	0,73 0,73
	20	25 26,9•	26 28	75	16	105	14	38	6	38 40	4	2,5	4	M 12	1,03 1,03
	25	30 33,7•	31 34,5	85	16	115	14	38	6	42 45	4	2,8	4	M 12	1,24 1,23
	32	38 42,4•	39 43,5	100	16	140	18	40	6	52 56	6	3	4	M 16	1,82 1,80
	40	44,5 48,3•	45,5 49,5	110	16	150	18	42	7	60 64	6	3	4	M 16	2,10 2,08
	50	57 60,3•	58 61,5	125	18	165	18	45	8	72 75	6	3,5	4	M 16	2,81 2,78
	65	76,1	77	145	18	185	18	45	10	90	6	3,5	4	M 16	3,40
	80	88,9	90	160	20	200	18	50	10	105	8	3,7	8*	M 16	4,20
	100	108 114,3•	109 115,5	180	20	220	18	52	12	125 131	8	3,7	8	M 16	4,90 4,75
	125	133 139,7•	134 141	210	22	250	18	55	12	150 156	8	4	8	M 16	6,70 6,45
	150	159 168,3•	161 170,5	240	22	285	22	55	12	175 184	10	5	8	M 20	8,30 8,00
	175	193,7	195,5	270	24	315	22	60	12	210	10	5	8	M 20	10,3
	200	219,1	221	295	24	340	22	62	16	235	10	5	12	M 20	11,1
	250	267 273•	269 275	355	26	405	25	70	16	285 292	12	5,5	12	M 22	16,7 16,3
	300	323,9	326	410	28	460	25	78	16	344	12	6	12	M 22	21,8
	350	355,6• 368	357,5 370	470	30	520	25	82	16	390	12	6,4	16	M 22	31,7 29,2
	400	406,4• 419	408,5 421	525	32	580	30	85	16	445	12	7	16	M 27	38,3 37,0
	450	457,2•	459	585	40	640	30	85	16	485	12	7,3	20	M 27	45,4
	500	508	510	650	44	715	33	90	16	548	12	7,3	20	M 30	61,1
	600	609,6	611,5	770	54	840	36	95	18	652	12	7,3	20	M 33	84,6
	700	711,2	715	840	36	910	36	100	18	755	12	9	24	M 33	87,4
	800	812,8	817	950	38	1025	39	105	20	855	12	9	24	M 36x3	109
	900	914,4	9,18	1050	40	1125	39	110	20	955	12	10	28	M 36x3	129
	1000	1016	1020	1170	42	1255	42	120	22	1058	16	12	28	M 39x3	175
	1200	1220	1224	1390	48	1485	48	130	30	1262	16	14	32	M 45x3	257
	1400	1420	1424	1590	52	1685	48	145	30	1465	16	16	36	M 45x3	337
	1600	1620	1624	1820	58	1930	56	160	35	1668	16	17	40	M 52x3	481
1800	1820	1824	2020	62	2130	56	170	35	1870	16	19	44	M 52x3	591	
2000	2020	2024	2230	66	2345	62	180	40	2072	16	21	48	M 56x4	727	